

NEW BONDWAY

London

DESIGN CONCEPT AND CONTEXT

Our aspirations for the site are to:

- Deliver high quality architecture which is distinctive and that contributes positively to the existing and emerging context in Vauxhall.
- Design buildings at a suitable human scale, massing and height, with the appropriate use of materials and detailing.
- Enhance the urban context through the provision of public open spaces, active retail frontages and pedestrian access links to the wider public realm.
- Create a diverse and sustainable community able to live and enjoy recreation in one place.
- Provide a generous, on-site, communal area for residents, including children's play areas.

The proposals have been designed around the concept of a composition of balance in order to deliver the optimum use of residential, office space, retail and amenity use at different heights, through a gracefully stacked composition.

The office space is located at the top of the south block above the affordable homes and will offer a unique office environment with stunning and expansive views of London. This volume acts as a bridge between the south and north buildings, which in turn creates an extensive space for amenity roof gardens for the residents.

The nature of the design also allows additional areas for indoor amenity rooms, an office atrium and residential winter gardens.



Composition of Balance



Oasis in the Sky



Axonometric of the Proposal

Massing Diagrams

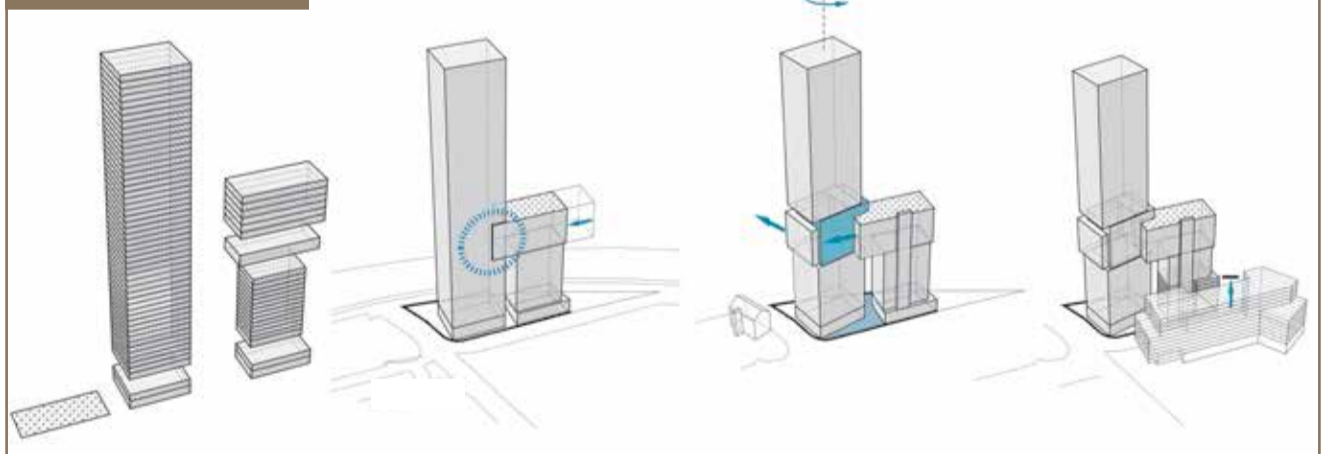

www.newbondway.co.uk



NEW BONDWAY
London